

# Design of an electrical drive for motorized bicycles

C. Boccaletti, G. Duni, P. Petrucci, E. Santini

Department of Electrical Engineering  
University of Rome "La Sapienza"  
Via Eudossiana 18, 00184 Rome, Italy  
Tel. +39 06 44585762, Fax +39 06 4883235  
e-mail: chiara.boccaletti@uniroma1.it

**Abstract.** The aim of this work is the design of an electrical drive for a motorized bicycle, characterised by new solutions for the control method and the regenerative braking system. A dynamic model of the vehicle has been realised, and the characteristics of the drive have been individuated. An effective closed-loop control strategy has been studied, adjusting the motor torque and the current in order to increase the availability range. Finally, a feasibility study of a regenerative braking system based on the supercapacitor technology has been carried out. All the components of the drive have been selected among the models available on the market. In the paper the results of the simulations are presented and other technical-economical aspects such as energy consumption and costs are also briefly discussed.

## Key words

Power-assisted bicycle, radial flux permanent magnet DC motor, supercapacitors, regenerative power control

## 1. Introduction

Human-powered hybrid electric vehicles can become a key to personal transportation in an environment where atmospheric pollution must be limited, where automotive traffic congestion is severe, and where parking space in urban centres is not available [1].

According to the European Law 2002/24/CE item h point 1, a power-assisted bicycle is a two or three wheels vehicle equipped with an auxiliary electric motor whose maximum nominal power is 0.25 kW.

Electrical bicycles offer extremely efficient, pollution-free transportation for urban and suburban areas, and the addition of electric drive extends their range.

Motorized bicycles are an economic and ecological vehicle suitable for all ages; the use of a helmet is not compulsory; they will not normally require registration and taxes, licensing or operator qualification [2, 3].

In this paper, the term "motorized bicycle" is used to describe a partially motor powered bicycle, commonly known as "pedelec" (*Pedal electric cycle*) [3].

The motor action is progressively reduced and finally interrupted if a 25 km/h speed is reached (such speed limit is imposed for security reasons), if the cyclist stops pedalling or if the brake is used. Pedalling is the main

form of propulsion, while the motor gives extra speed, especially uphill.

The electrical drive consists of four main components:

- 1) a motor
- 2) a power transmission system
- 3) a control system
- 4) a battery pack

The battery pack and thus the vehicle autonomy is the main aspect to be focused on. In this sense, a closed loop control circuit for the output power control has been studied to be implemented in the electrical drive, avoiding undesired accelerations and increasing the battery range. Such a solution is not commercially available.

The recovering of the braking energy by means of the supercapacitor technology can determine a reduction of the electromagnetic stresses on the battery pack, and therefore a longer battery life.

## 2. Electrical Drive Design

The power propelling a bicycle and rider goes mostly into overcoming wind resistance and lifting mass up hills at normal bicycle speeds [2, 3].

Bearing and tire friction are small but can equal wind resistance at very low speeds.

The electric motor torque curve is a function of road slope  $p$ , rolling friction coefficient  $C_{roll}$  (whose value depends on the road conditions), wind speed  $V_w$ , cyclist resistance coefficient  $C_r$ , and total mass  $m$  of the bicycle-cyclist system. Equation (1) represents the equilibrium and equation (2) keeps the bluff body pressure drag and skin friction drag into account.

$$T_{tot} = T_{air} + T_{slope} + T_{friction} \quad (1)$$

$$C_{air} = \frac{C_r \cdot A \cdot \rho}{2} \cdot (V_c + V_w)^2 \cdot b \quad (2)$$

Experimental elaborations have been performed to estimate the total torque variation in function of speed with three standard slope grades: 1%, 10% and 12%. Fig. 1 shows that, moving from a flat road to a climb, the total requested torque passes from 2.17 Nm to 19.43 Nm,

for a 7.2 km/h speed. Fig. 2 shows the influence of the total mass of the system on the required power. Provided that the cyclist is pedalling, the above mentioned law does not fix any constraint on the level of the assistance. However it strongly affects the battery autonomy.

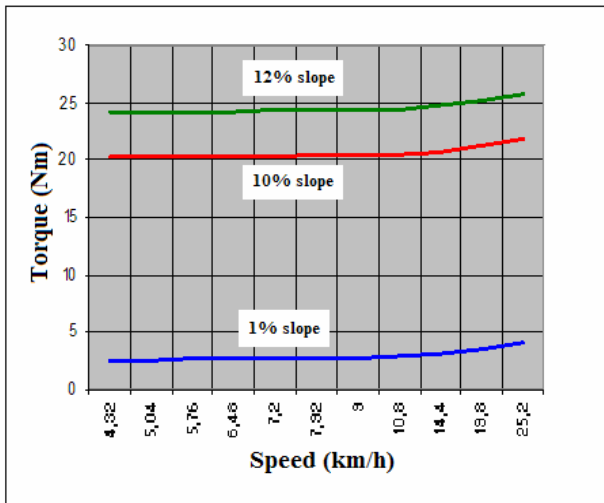

Fig. 1. - Slope influence on the total torque for a 80kg cyclist

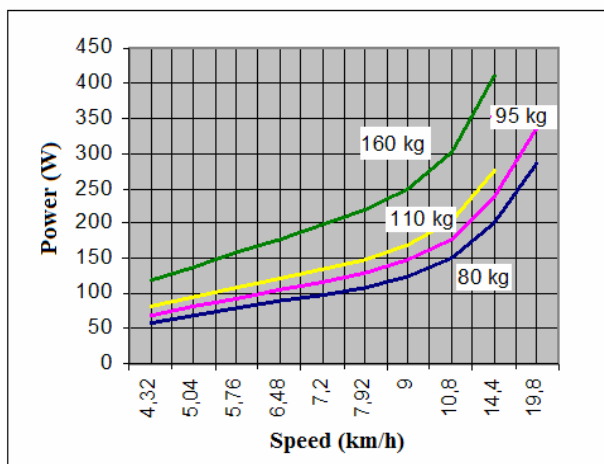

Fig. 2. - Mass influence on the total required power

### 3. Choice of the Electric Motor

Two different types of motors are commonly chosen for the auxiliary drive of such vehicles: DC Brushed motors and radial flux DC Brushless motors with permanent magnets (RFPM). Mostly for its reduced size and higher efficiency a DC Brushless motor with a particular shape – a so-called hub motor - has been chosen (external rotor and internal stator).

For this work a 0.25 kW three-phase brushless motor has been selected. It has an internal stator solidal with the wheel hub and an external rotor rotating at the wheel speed. The electric machine is positioned on the front wheel for a simpler installation. The power transmission system is of the direct drive type, so that gears and coupling joints are avoided.

A closed loop commutation system makes it possible to regulate the machine voltage and then to control the absorbed current. The load torque depends on the road itinerary; according to the mechanical assistance level,

the control system will regulate the voltage so to obtain the correct current and torque value. Such a closed loop control system is not available on the pedelec market. This kind of regulations also allows estimating the battery state of charge and operating to improve the battery autonomy.

A constant value of phase current is imposed; such value remains constant until a speed value  $n_n$  is reached. It is possible to estimate the electrical power required by the motor. For the present case a limit  $P_n = 250$  W is fixed by the law, corresponding to speed  $n_n$ .

Therefore, the operation is limited by a curve in which electromagnetic torque and speed change in a way that the power absorbed by the motor is constant (see Fig. 3).

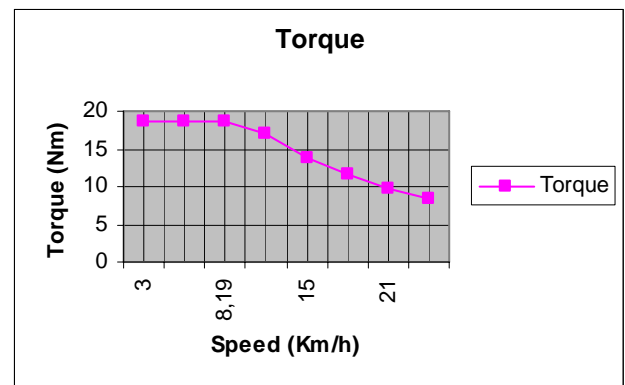

Fig. 3. - Operating limit for the DC brushless machine

### 4. Control System

The combination between the cyclist muscular power and the power of the motor are optimised by means of a specific control system that can manage the power inputs in the different load conditions.

The basic configuration for a pedelec can be represented by the following scheme (Fig. 4) in which the power flows are shown [3].

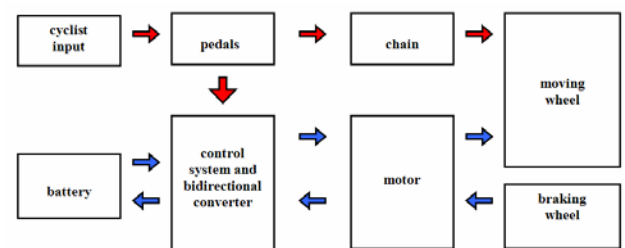

Fig. 4. - Power flows

As it is evident from the scheme, the cyclist input is the condition to obtain assistance from the electric motor. A sensor will have to determine the motion direction if a muscular propulsion is present, regardless of the road conditions and slope.

The control system is made up by the following main components: three rotor position Hall transducers with decoder logic circuits, a main inverter for the alimentation of the motor and the imposition the specific current waveform for each load condition, a bidirectional converter to allow current flow between the battery pack and the motor, proportional-integral regulators to manage

the signal coming from the comparison between the reference current and the one measured at the motor, a Pulse Width Modulator (PWM) inverter for the generation of the reference current system. Starting from the equivalent circuit of a brushless dc motor and its equation (3),

$$V(s) = R \cdot I(s) + s \cdot L \cdot I(s) + E(s) \quad (3)$$

as the induced emf depends on the motor rotation speed, by means of the Hall transducer it is possible to obtain the instantaneous speed that leads to an induced emf  $\hat{E}(s)$ . With a good approximation  $\hat{E}(s)$  can be considered equal to the ideal induced emf  $E(s)$ . Adding those quantities in the third node of the scheme in Fig. 5, the system remains independent from such electrical parameter.

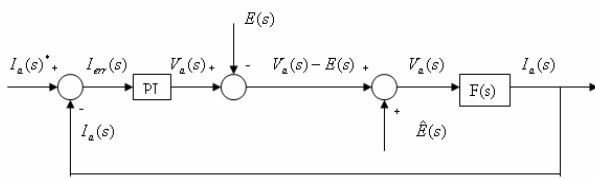

Fig. 5. - Closed loop regulation of phase current  $i_a$

The transfer function  $F(s)$ , representing the dc motor, shows a pole that strongly influences the system output. The presence of a proportional-integral regulator offers a solution to such a limitation.

The expression of the closed loop transfer function  $W(s)$  presents a pole that depends on the phase total resistance and on the constant of the integral regulator  $K_i$  which allows to manage the system output within a range of variations of the input signal.

To optimise the drive operation, the electromagnetic torque should be independent from the angular position of the rotor. In other words, the phase difference between the magnetic field produced by the permanent magnets and that produced by the stator currents should be maintained equal to  $90^\circ$ . A particular current commutation sequence has to be imposed.

The presence of the three Hall-effect sensors allows to know the instantaneous rotor position and to perform a correct phase current commutation.

The regulator output voltage signal is sent to and compared with the constant frequency triangular signal, in order to generate the static switch command signals of the power inverter.

Starting from a generic rotor position  $\theta$ , being  $i_c$  zero, and having the currents and the induced emf's the same magnitude, the torque is

$$T_e = \frac{e_a \cdot i_a + e_b \cdot i_b + e_c \cdot i_c}{\omega_r} = \frac{2 \cdot e \cdot i}{\omega_r} \quad (4)$$

This expression keeps its validity for any  $\theta$ , if a rectangular current waveform is chosen in the stator phases.

By means of the studied closed loop control system, for each load condition the motor supplies the correct torque, depending on the level of assistance required, avoiding

unwanted accelerations with a consequent improvement of the battery autonomy.

### A. Bidirectional converter

Such converter allows the current flow in both directions: from the battery to the motor when the electrical machine is working as a motor, to the battery, when it is working as a generator.

In the motor mode, as mentioned above, the main condition to obtain the motor assistance is that the cyclist is pedalling in the forward direction.

The converter, in the step-down mode, assures a constant link voltage value for sourcing the inverter. It has to keep the link voltage independent from the battery output voltage ( $V_d$ ) which is connected with its state of charge. Fig. 6 shows a scheme for the step-down converter.

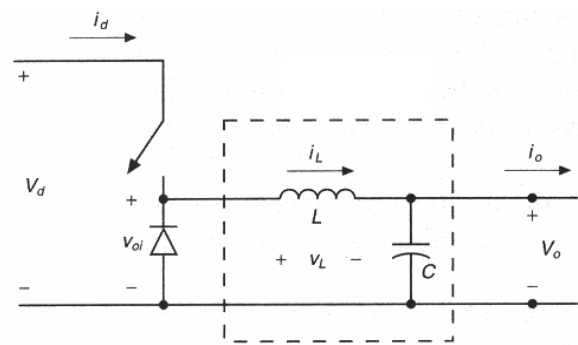

Fig. 6. - Step-down converter

When the electrical machine is working in the generator mode, the current flows toward the battery pack for the regenerative braking. In this condition it is necessary to use a step-up converter (Fig. 7)

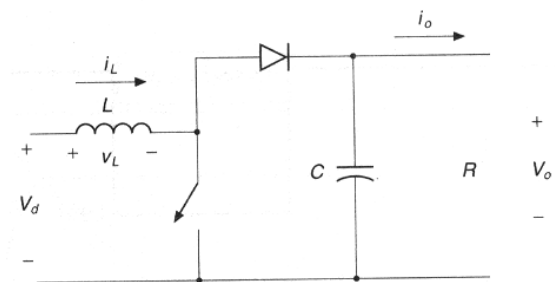

Fig. 7. - Step-up converter

## 5. Regenerative Braking

The battery types chosen in this work are Nickel Metal Hydrate with a nominal voltage of 36V and a 9Ah capacity.

Since the level of assistance is strongly influenced by the battery range, the management of the battery charge and discharge phases is particularly important.

The possibility to recover the braking energy is of great interest in designing the electrical drive. The regenerative power control for electric bicycle method is a simple and low-cost solution [5].

Under appropriate conditions, the batteries can be recharged. During a deceleration or braking, an amount

of kinetic energy is usually lost as friction on the wheel. The regenerative braking system allows recovering part of such kinetic energy, to be used to feed either the battery or the electrical drive.

The intermittent characteristic of the itinerary lead by the rider can be smoothed by the introduction of a supercapacitor bank. As it is known, a supercapacitor can store amounts of energy and then distribute it depending on the required power, minimising the energy losses.

The supercapacitor bank raises the total weight of the drive of approximately 3kg, but avoids the electromagnetic stresses on the main source of the pedelec, improving the battery performance and increasing the autonomy and the life of the battery itself.

Under specific conditions, imposed by a bidirectional converter, in a particular time interval a regenerative brake can be obtained.

The core of the system is represented by a Buck-Boost converter with IGBT power static switches. The Boost side is connected to the supercapacitors bank, the Buck side to the battery pack (see Fig. 8).

The control system measures the following quantities: the battery and the supercapacitors bank voltages, the state of charge of the battery, the bicycle speed, and the instantaneous currents on the load and on the supercapacitors bank. A microcontroller elaborates those quantities and generates a commutation sequence by means of the PWM technique to control the power static switch.

When the bicycle exceeds a certain speed, the microcontroller lets the supercapacitors discharge; if the vehicle is stopped, the supercapacitors are charged, storing the accumulated energy.

The battery voltage level indicates how the vehicle is moving: acceleration leads to its reduction, in the opposite case, it leads to its increase, and the regenerative braking happens. In the latter case the control system activates the Buck converter to store part of the kinetic energy in the supercapacitors bank.

During the acceleration phase  $T_1$  is in switch mode allowing energy transfer from the supercapacitors to the battery. In the regenerative phase (deceleration)  $T_2$  is in switch mode allowing an opposite energy flow. This last operation is only possible when the cyclist stops pedalling. The brake lever allows two different modes: electromagnetic and mechanical.

The above mentioned operations are managed by the microcontroller and its function is the combination of two main control levels: primary and secondary.

The first aims at generating a reference current  $I_{ref}$  to be feed to the supercapacitos bank, in any load condition. Its inputs are: load current  $I_{load}$ , battery voltage  $V_{bat}$ , and supercapacitors voltage  $V_{cap}$ . This first control maintains the right energy level inside the supercapacitors bank by means of the bicycle speed  $V_c$  and of the state of charge of the battery.

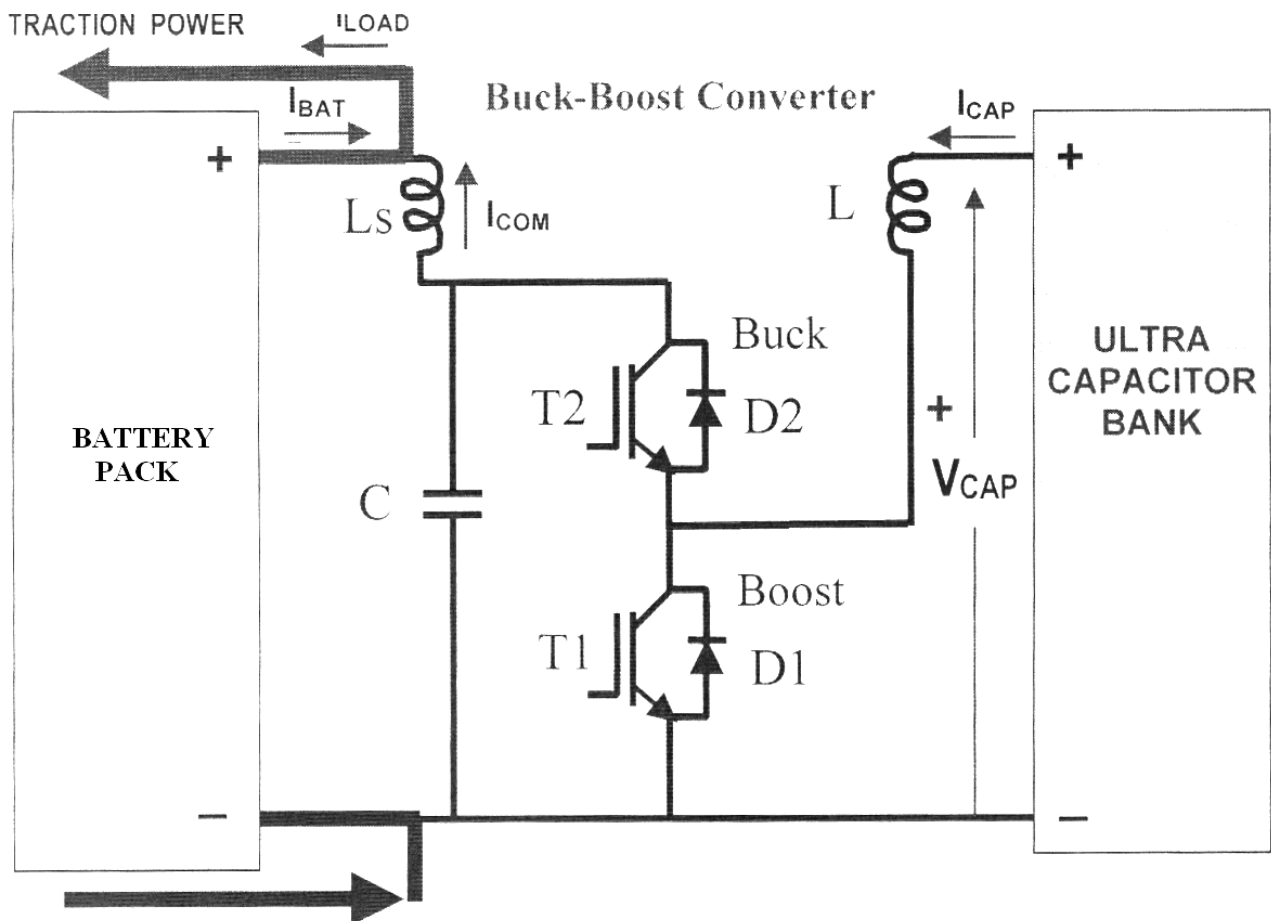

Fig. 8. - Control system for the regenerative braking

$I_{ref}$  is sent to the second level control, where the current to compensate the supercapacitors charge will be calculated. In this level the PWM signal is generated. As an example, Fig. 9 and Fig. 10 show some results of the simulations for the acceleration and deceleration (braking) phases.

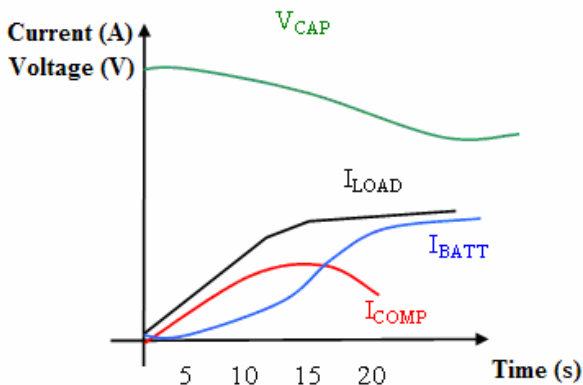

Fig. 9. - Acceleration phase

In the first case it has been considered an acceleration from 4km/h to 8km/h. In the second case the cyclist stops pedalling.

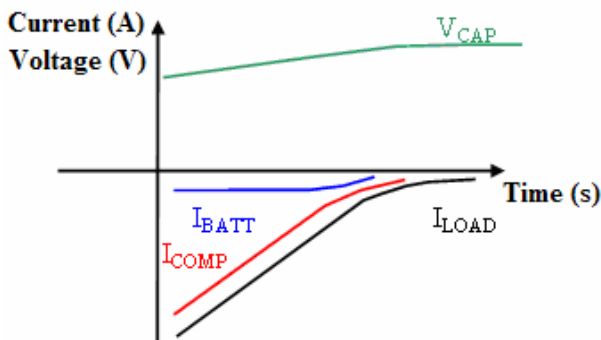

Fig. 10. - Regenerative braking phase

With the above technical solutions, a performance improvement up to 15-20% can be obtained.

## 6. Conclusions

A number of different aspects thrust the use of electric bicycles in different situations. These include lower energy cost per distance travelled for a single rider, savings in other costs such as insurances, licenses, registration, parking, improvement of the traffic flow, environmental friendliness, and the health benefit for the rider.

In the paper, the design of an electrical drive for a motorised bicycle is described, using commercial components available on the market.

On the basis of technical-economical consideration, the feasibility of such a system for industrial production has been analysed.

A dynamical model has been used to simulate the system behaviour in a number of different situations. A closed-loop control circuit allows the optimisation of the

component operation, determining in particular a proper value of the motor torque with respect to the load and of the absorbed current. In this way, undesired accelerations can be avoided and the battery range can be increased. Also a suitable regenerative braking system, based on the supercapacitor technology, has been studied. Such a system can reduce the electromagnetic stresses of the battery pack increasing the battery life and reducing the maintenance costs (periodic substitutions).

## References

- [1]. H. Oman, W. C. Morchin, F. E. Jamerson (1995), Electric-bicycle propulsion power, *Microelectronics Communications Technology Producing Quality Products Mobile and Portable Power Emerging Technologies*, p 555
- [2]. W.C. Morchin (1994), Battery-powered electric bicycles, *Northcon/94 Conference Record*, pp 269 – 274.
- [3]. A. Muetze, Y. C. Tan (2005), Performance evaluation of electric bicycles, *Industry Applications Conference*, Volume 4, pp 2865 – 2872
- [4]. E. Starschich, A. Muetze (2007), Comparison of the Performances of Different Geared Brushless-DC Motor Drives for Electric Bicycles, *Electric Machines & Drives Conference IEEE International*, Volume 1, pp 140 - 147
- [5]. N. Somchaiwong, W. Ponglangka (2006), Regenerative Power Control for Electric Bicycle, *SICE-ICASE International Joint Conference*, pp 4362-4365