

OPTIMAL RELAY PERFORMANCE USING ADVANCED FAULT DIAGNOSTIC TECHNIQUES

Tolu.O. Akinbulire, Peter.O. Oluseyi and Chris.I.Esumeh

Department of Electrical/Electronics Engineering

University of Lagos,

Akoka, Yaba, Lagos, Nigeria.

takinbulire@unilag.edu.ng ; poluseyi@unilag.edu.ng

Abstract:

This paper describes application of Artificial Intelligence (AI) methods in the diagnostic operation of the protective relays in power system with a particular emphasis on neuro-fuzzy method, as a viable enhancement to the existing classical protection technique in use on the Nigeria's national grid. The proposed method is simulated to showcase its advantages over the existing methods. It will not replace the latter but rather serves as a means of improving its reliability as a protection scheme.

This work can also be applied to any other complex power system spread over a wide geographical area like Nigeria's.

Key words: relay,neuro-fuzzy,fault, protection,

1. Introduction:

The protective relay [1, 2] is arguably the most important component in the electrical power system (EPS) in ensuring the reliability and security of system operation. Protection is especially important for transmission lines. Since the lines are mostly extended across large geographical regions to transport the power from generators to load centers Hence it is possible that they can easily experience faults along the transmission line which ranges from conduction path failure to loss of insulation. Figure 1 below shows a typical protective relay position and

configuration of a section of the Nigeria's Electric Power System.

For some time now, the fault diagnostic mechanism employs a combination of the application of voltage/potential transformers (VT/PT), current transformers (CT) and the protective relay which serves the purpose of detecting abnormal conditions and initiating circuit breaker's action to isolate faulty a faulty portion and/or components in the system. Obviously, a speedy response guarantees no or minimal damage to system equipment.

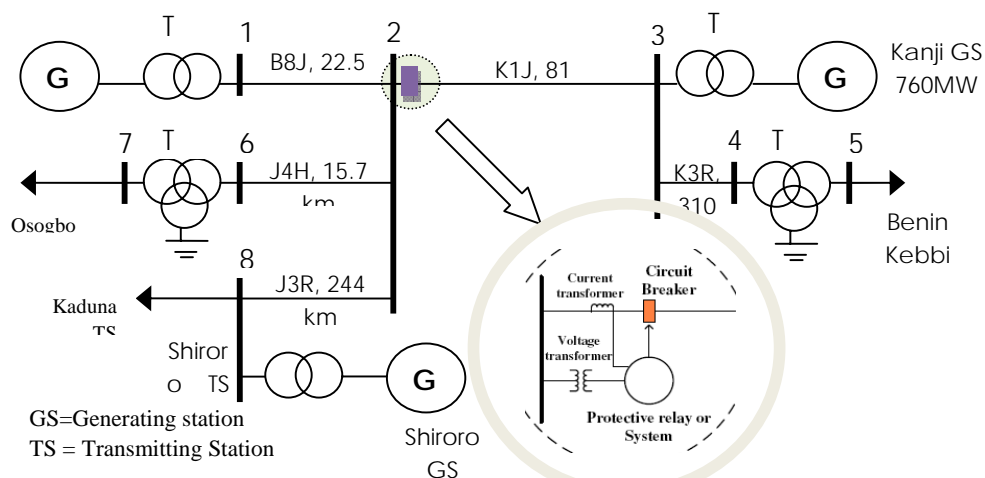

Fig. 1: Nigeria's Electric Power System (Section)

The effective performance of a protection system is measured by several criteria such as selectivity/discrimination, reliability, and speed of operation. This suggests that the relay must possess the “intelligence” to explicitly differentiate a fault from a non-fault situation before carrying out its operation. The associated difficulty results mainly from the trade-off between the security demands (no false tripping), the speed of operation and the dependability (guaranteed operation) requirements. The more secure the relay, the more it tends to operate slowly. On the other hand, the faster the relay, the more it tends to blunder.

There are two categories of fault diagnosis systems namely: hardware redundancy or analytical redundancy [3, 4]. To ensure the protection system maintains dependability when protecting the equipment, a backup scheme is provided for each relay since greatest care in the manufacture and installation of equipment is never an altruistic avenue for total elimination of the possibility of defect in a system mechanism.

Thus, hardware redundancy utilizes duplication of actual physical devices: voltage or potential transformer (VT or PT), current transformer (CT), breaker trip coil, or protective relay itself, and a voting system to detect the occurrence of a fault and its location in the system. The primary and backup relays work in parallel to trip the same circuit breaker but a time delay must be incorporated to separate trip signals from either of the two relays.

To achieve a better performance, backup relays may use a different operating principle from that of the primary relays and are to be supplied from separate CTs. The main disadvantages of this approach are the significant cost of the extra equipment required and the increased parasitic therefore duplication would be warranted only on very important interconnections which is justified by increased expenses and complexity. This is illustrated by figure 2.

On the other hand, analytical redundancy as its name implies uses redundant functional relationships between variables of the system.

The main advantage of this approach compared to hardware redundancy is that no extra equipment is necessary. Analytical redundancy is further subdivided into two generic forms based on different approaches namely: the model based approach and the data-based approach [4,7].

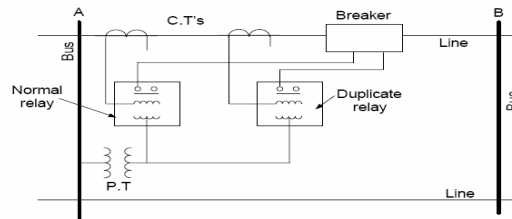

Fig. 2: hardware redundancy with Relay set-up

In the model-based approach, the engineer has access to a model of the monitored system. The model could be analytical, or knowledge-based. Most applications of this approach have dealt with linear systems, since they can be easily described and studied.

While, in the case of the data-based approach, one bypasses the step of obtaining a mathematical model and deals directly with the data. This is more appealing when the process being monitored is not known to be linear or when it is too complicated to be extracted from the data. It is this approach which we will concentrate on in this paper in order to evaluate the potential of neural networks as fault discriminators.

This work tries to investigate a new method of transmission line fault diagnosis using advanced technologies by integrating this new transmission line fault detection tool with the traditional relays so as to achieve optimal improvement in the overall performance of transmission line protection system. The study will focus on the strengths of the neuro-fuzzy based relay scheme which, given its operating principle, could be easily integrated into the current relay schemes. This technique which uses the time-domain samples as input [5,6,7,8].

The paper is organized as follows: Section 2 restates the mathematical diagnosis of relay fault

analysis. Section 3 introduces approach for implementation of solution with the hardware and software modules for proposed protective relaying solution using the complex neuro-fuzzy abstraction mechanism. Then lastly the method is applied to a selected model of the practical power network. While the conclusion is drawn from the results obtained.

2. Problem Formulation

There are four different types of fault in power systems namely single phase to earth, phase to phase, phase to phase to earth and three phase faults. In a Red-Yellow-Blue(RYB) three phase network, the four fault types can be subdivided into 11 cases [3,5]. In order to completely analyze the operation of relays during fault detection, it is essential to demonstrate mathematically the anomalies that persist with the occurrence of typical fault types in power systems.

These various types of fault can be resolved using the fault analysis approach that takes into consideration positive sequence, negative sequence and the zero sequence [1,3]. Hence it is not difficult to envision the characteristics of the given fault types when provided with this simplification technique. Using figure 3 as a case study for this analysis, we have the attendant matrix and its solution shown below.

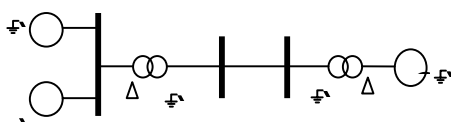

Figure 3: single phase fault to earth on red phase
From the symmetrical component rule, it is common place to visualize the relationship between actual phase values and sequence values as[8]:

$$\begin{bmatrix} I_r \\ I_y \\ I_b \end{bmatrix} = \begin{bmatrix} 1 & 1 & 1 \\ h^2 & h & 1 \\ h & h^2 & 1 \end{bmatrix} \begin{bmatrix} I_{r1} \\ I_{r2} \\ I_{r0} \end{bmatrix} \quad (1)$$

Where , $h = 1 < 120^\circ$.

$$h^2 \quad h \quad 1$$

Using network reduction techniques or otherwise, each sequence network can be replaced by single impedance values and for respective sequences.

The following equations are thus derived from the reduced circuit:

From eqn (1) ,the voltage on the red phase is given by:

$$V_r = V_{r1} + V_{r2} + V_{r0} = 3I_{r0}Z_f \quad (2)$$

This shows that the voltage on the faulted phase reduces to zero for a complete short circuit fault or the voltage across the fault impedance. Similarly the voltage on the yellow phase is:

$$V_y = V_{r0} + h^2V_{r1} + hV_{r2} \quad (3)$$

$$V_y = 3I_{r0}Z_f + V_{r1}(h^2 - 1) + V_{r2}(h - 1) \quad (4)$$

This also shows the phasor change in the nominal voltage across the yellow phase with respect to the prefault red phase voltage. For the blue phase,

$$V_b = V_{r0} + hV_{r1} + h^2V_{r2} \quad (5)$$

$$V_b = 3I_{r0}Z_f + V_{r1}(h^2 - 1) + V_{r2}(h^2 - 1) \quad (6)$$

3. Solution Approach

It is possible to configure protection or control schemes involving a fuzzy processing module augmented with other techniques such as neural networks, wavelet transformation, etc. The resulting hybrid structures combine the strengths and compensate for weaknesses of the individual techniques, which bring about increased efficiency and reliability of the scheme. Some applications of fuzzy hybrid solutions are fuzzy-wavelet scheme for fault classification and location as well as fuzzy-neural distance protection.

In the field of artificial intelligence, neuro-fuzzy refers to hybrids of artificial neural networks and fuzzy logic. This hybridization results in an intelligent system that synergizes these two

techniques by combining the “intuitive” reasoning of fuzzy systems with the learning and connectionist structure of neural networks; widely termed Fuzzy Neural Network (FNN) or Neuro-Fuzzy Systems. The performance of neuro-fuzzy systems involves two contradictory requirements in fuzzy modeling: interpretability versus accuracy [4,6]. A functional block diagram of proposed hardware and software solution for protective relaying based on the composite neuro-fuzzy approach is shown in Figure 3. Digital relays generally consist of three functional hardware subsystems: a signal conditioning subsystem, digital processing subsystem and command execution subsystem .

The crucial factor is the software realization of the proposed algorithm since the distance principle is still being incorporated. The algorithm is simply a mathematical formulation of steps taken to retrieve input data from the power system, determine the fault type classification and recommend regulatory action to the circuit breaker. The relay should show improvement over traditional relays especially in the aspect of relay misoperations[6].

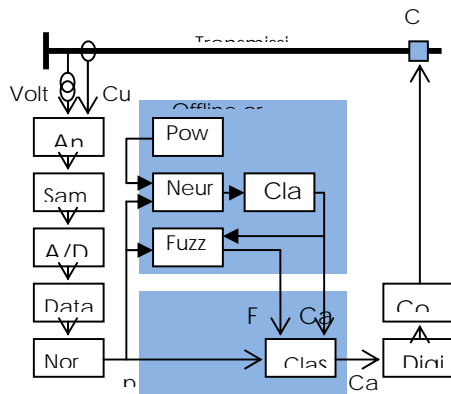

Figure 4: Propose protective relaying based on Neuro-fuzzy

4. Test Results

The following results were obtained from the training simulation applied on a simplified real problem with a concise number of training patterns. Training patterns, shown in the two dimensional graph of figure 4 were generated by

simulating a three phase to ground fault, combining 12 values of fault inception angle and 5 values of fault resistance generating a total of 60 patterns for this case. The symbols used for showing the patterns correspond to different types of the fault.

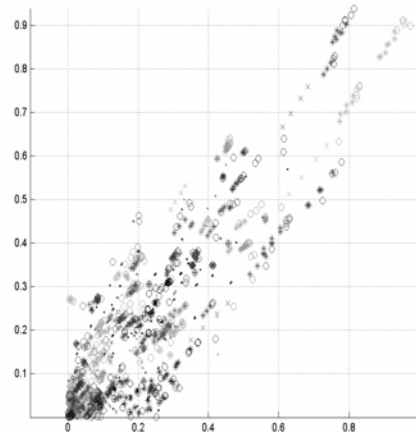

Figure 5: Initial training patterns

In the stabilization phase, well defined clusters have been formed and new clusters can also be identified. Most of the patterns are grouped into clusters, although some patterns lie outside clusters.

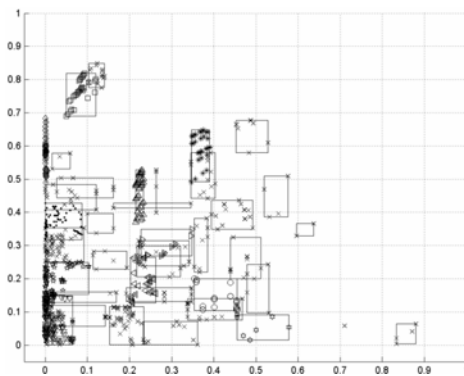

Figure 6: supervised and unsupervised learning clusters

In the stabilization phase, well defined clusters have been formed and new clusters can also be identified. Most of the patterns are grouped into clusters, although some patterns

lie outside clusters Error in detection can be determined during nominal and varying frequency scenarios respectively. However, source variations take a larger toll on the networks resulting in more predictive errors . With a much more extensive data set and better tuned classifier with improved supervised learning stages, accuracy of the system especially in cases of source variation could be further improved with stringent error margins.

The consistency of electricity supply is a major indication of economic and technical development of a nation. Relay “misoperations” is believed to be one of the most contributing factors to the blackouts and power outages. Lack of intuitive verification mechanism for relay operation is also a hindrance to a corrective control in such cases.

5. Conclusion:

Since competition is driving the power industry from where it was in the last century then a utility company needs to supply uninterrupted electricity to its consumers continuously in order to avoid being run out of market and this model presented a good report for fast clearance of faults. Interesting results related to the neuro-fuzzy recognition algorithm have already been achieved which makes this work a piece of good beginning for avoiding network disruption in Nigeria and

References

[1]. M. Kezunovic, S. Vasilic and D. Ristanovic, “Interfacing Protective Relays and Relay Models to Power System Modeling Software and Data Files,” Department of Electrical Engineering, Texas A&M University, College Station.

The study presents a unique artificial intelligence based solution for high-speed protective relaying. Its algorithm selects the most representative input data set and applies them in establishing stable pattern prototypes during unsupervised and supervised training/learning phases. The algorithm is further extended during implementation by overriding the crisp K-Nearest Neighbor with its fuzzy counterpart, which establishes a finer grating of membership degree assignments using its fuzzy decision rule to achieve more accurate categorical classifications for novel encountered patterns.

Future work will be comparing this approach with the existing techniques. Effort will also be put into sharper feature extraction with independent pattern scaling and refining supervised learning procedures to establish unique homogenous cluster structures that constitute better defined categories.

elsewhere. Information Technology (IT) in substations promises significant developments to reduce costs and improve operating performance, as well as to enhance information management. Substation automation will allow on-line control and monitoring of primary and secondary equipment.

[2]. Cansın Y. Evrenoso and Ali Abur, “Travelling Wave Based Fault Location for Teed Circuits,” Department of Electrical Engineering, Texas A&M University, College Station

[3] J. Lewis Blackburn, Protective Relaying: Principles and Applications, New York: Marcel Dekker, Inc., second edition, 1998.

- [4] Adriana Castro, Vladimiro Miranda, "Mapping Neural Networks into Rule Sets and Making Their Hidden Knowledge Explicit," 14th PSCC, Sevilla, session 20, June 2006, p. 3.
- [5]. Alireza Daneshpooy, "Artificial Neural Network and Fuzzy Logic Control for HVDC Systems," PhD. Thesis, Department of Electrical and Computer Engineering, University of Manitoba, July 1997.
- [6]. S. Vasilic, "Fuzzy neural network pattern recognition algorithm for classification of the events in power system networks," Ph.D. dissertation, Texas A&M University, College Station, Texas, 2004.
- [7] Jie Tang, "Wide Area Differential Protection system" ,PhD Thesis ,Department of Mechanical Engineering, Famu-Fsu College of Engineering, March 2006.
- [8] Hadi Saadat, Power System Analysis, Tata-McGraw Hill, New Delhi, 2004, pp 399-403.