

Multi-Level Representation for the Control Design of a Super Capacitor Storage System for a Microgrid Connected Application

P. LI^{1,2}, Ph. Degobert², B. François¹ and B. Robyns³

Laboratoire d'Electrotechnique et d'Electronique de Puissance de Lille (L2EP)

¹ Ecole Centrale de Lille, Cité Scientifique, BP 48, 59651 Villeneuve d'Ascq Cedex, France

² Ecole Nationale Supérieure d'Arts et Métiers, 8 Boulevard Louis XIV, 59046 Lille Cedex, France

³ Hautes Etudes d'Ingénieur, 13 Rue de Toul, 59046 Lille Cedex, France

e-mail: lephis@gmail.com, philippe.degobert@lille.ensam.fr, bruno.francois@ec-lille.fr, benoit.robyns@hei.fr

1. Introduction

In this paper an average multi-level representation of power electronic converters is used to design a dynamic model of a Super Capacitor Bank for a microgrid application installed at the laboratory L2EP-ENSAM Lille [3][4]. Fig. 1 shows the studied hybrid system based on a 17.3kWpeak photovoltaic system associated with a 28kWelectric Capstone micro turbine and a 72F/96V Maxwell Super Capacitor Bank (SCB). A great interest of the power storage is that the super capacitor has a quick dynamic response time to reduce the power variation in the microgrid. A dedicated multi-level representation has been developed in order to propose a synthetic and dynamical description of the electromechanical conversion systems for microgrid applications. This description is an expansion of the Energetic Macroscopic Representation (EMR) [5] and allows the subdivision of the whole complex system into simple blocks. The expansion by multi-level representation integrates a power flow level, a power calculation level and their corresponding control levels, since the power flow is the most important factor for the supervision of microgrid units. A Maximal Control Structure can be deduced from the multi-level modeling through specific inversion rules. The proposed global model is simulated with the help of Matlab-SimulinkTM.

Key words

Super Capacitor Bank, microgrid, distributed generation, control design, multi-level representation.

2. SCB multi-level modelling and control

The SCB is composed of the Super Capacitor (SC), a SC filter, a chopper, a DC bus, an inverter and a three-phase grid filter. The complete multi-level modeling of the SCB is composed of three levels: *EMR*, *Power Calculation* and *Power Flow*. The control task is to reduce the power variations of the microgrid. The inverter is used to control the real and reactive power at the connection point. The control input of the chopper is used to control DC bus voltage. The control system is ordered by the steps according to the rules of the multi-level representation (fig. 2).

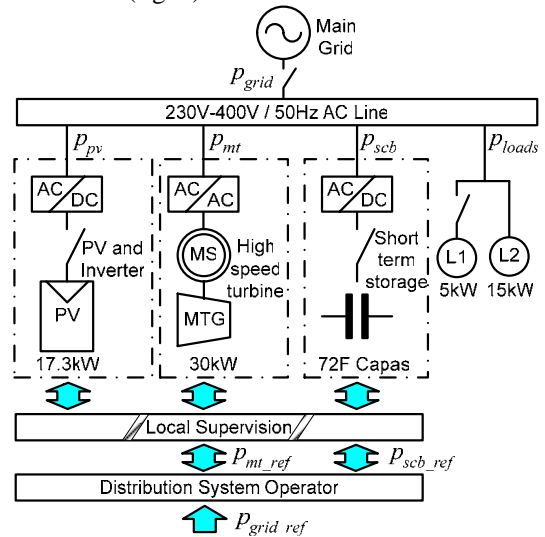

Fig. 1: PV/MTG/Super capacitor Microgrid scheme

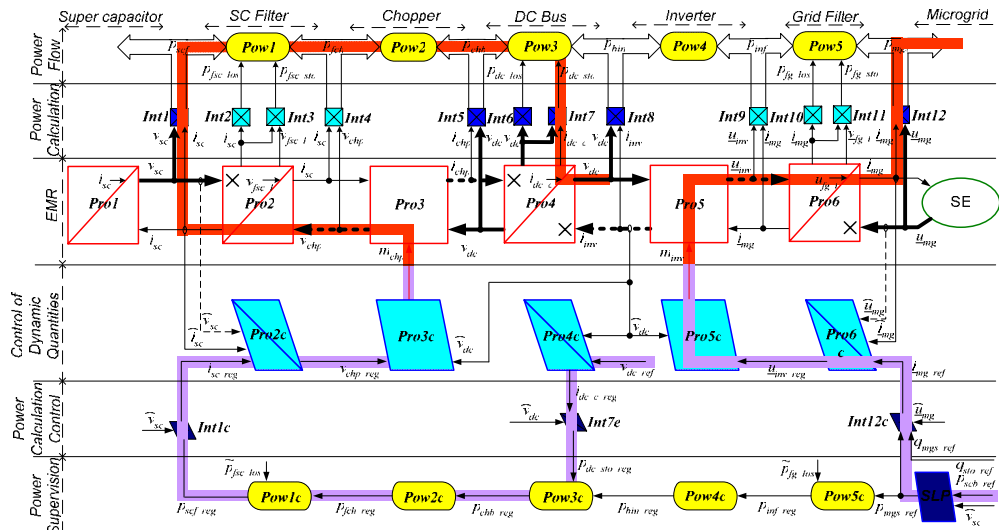

Fig. 2: Modeling and control system of the Super Capacitor Bank

3. Simulation results

Fig. 3 represents experimental variations of the real power of the studied microgrid. In order to evaluate our model we simulate it with two real power steps (at 40s and 100s) of the total microgrid loads (fig. 3.a). The photovoltaic power plant generation is set to the Maximal Power Point Tracking (fig. 3.b), which is proportional with the irradiance. The microgrid power generation reference is set to one real power step (at 150s, fig. 3.c), and the sensed power between the microgrid and the main is very close to the power reference, which is given by the Distribution System Operator. The microgrid power measurement is well followed by his reference (fig. 3.c). At 40s and 100s there are two peaks, which generated by the sudden connection and disconnection of a 5kW load, but later the microgrid power is corrected quickly by the SCB. The micro turbine tries to slowly compensate the fluctuations of the difference between the microgrid reference power and all the passive power variations of the microgrid (PV power and total loads) (fig. 3.d). The fast power fluctuations due to the slow response time of the micro turbine are reduced by the short term energy storage system – SCB (fig. 3.e).

4. Conclusion

A multi-level representation method to design the control system of a SCB is presented in this paper. It is composed of three modeling levels (*EMR*, *Power Calculation* and *Power flow*) and three corresponding control levels (*Control of Dynamic Quantities*, *Power Calculation Control* and *Power Supervision*). The interest of this multi-level representation method is the facility and the quickness for the control design, which uses the power flow for microgrid applications. The real power dispatching algorithm in the microgrid center supervision bloc is detailed in order to clarify the SCB power reference calculation. The simulations results validate this particular control design.

Acknowledgement

This work has been supported by the French National Agency of the Research (ANR SuperEner Project).

References

- [1] R. Lasseter, A. Akhil, C. Marnay, J. Stephens, J. Dagle, R. Guttromson, A. Sakis Meliopoulos, R. Yinger, and J. Eto, Integration of Distributed Energy Resources – The MicroGrid Concept, CERT MicroGrid Review, Feb 2002.
- [2] Abu-Sharkh S. et al., Can microgrids make a major contribution to UK energy supply?, Renewable and Sustainable Energy Reviews, 10, (2006), pp. 78-127.
- [3] Ph. Degobert, S. Kreuawan, X. Guillaud, Micro-grid powered by photovoltaic and micro turbine, International Conference on Renewable Energy and Power Quality (ICREPQ'06), CD-ROM, Palma de Mallorca, Spain, April, 2006
- [4] Ph. Degobert, S. Kreuawan, P. Li, B. François, Reduction of Fast Fluctuations of Power in a Microgrid with Super Capacitors, ESSCAP'06, CD-ROM, Lausanne, Switzerland, Nov. 2006.

- [5] A. Bouscayrol, Ph. Delarue, X. Guillaud, Power strategies for maximum control structure of a wind energy conversion system with a synchronous machine, Renewable Energy, vol. 30, pp. 2273-2288, May 2005.
- [6] Maxwell technologies application note, How to determine the appropriate Size Ultracapacitor for your application, document 1007236, Rev 2, October 2004.
- [7] L. Zubieta, and R. Bonert, Characterization of double-layer capacitors for power electronics applications, IEEE Trans. Ind. Appl., Vol. 36, no. 1, pp. 199-205, 2000.
- [8] B. Robyns, Y. Pankow, L. Leclercq, B. François, Equivalent continuous dynamic model of renewable energy system, Proceedings of the 7th International Conference on Modeling and Simulation of Electric Machines, Converters and systems, ELECTRIMACS 2002, Montreal, Aug., 2002.
- [9] P. Li, Ph. Degobert, B. François, B. Robyns, Multi Time Scale Modelling for the Control Design of a Grid Connected Micro Turbine Generator by Power Electronic Converters, International Symposium on Industrial Electronics (IEEE-ISIE 2006), ETS-Downtown Montreal (Quebec), Canada, July 2006, CD-ROM.
- [10] P. Li, Ph. Degobert, B. François, B. Robyns, Power Control Strategy of a Photovoltaic Power Plant for Microgrid applications, ISES Solar World Congress 2007 (SWC 2007), Beijing, China, September 2007.

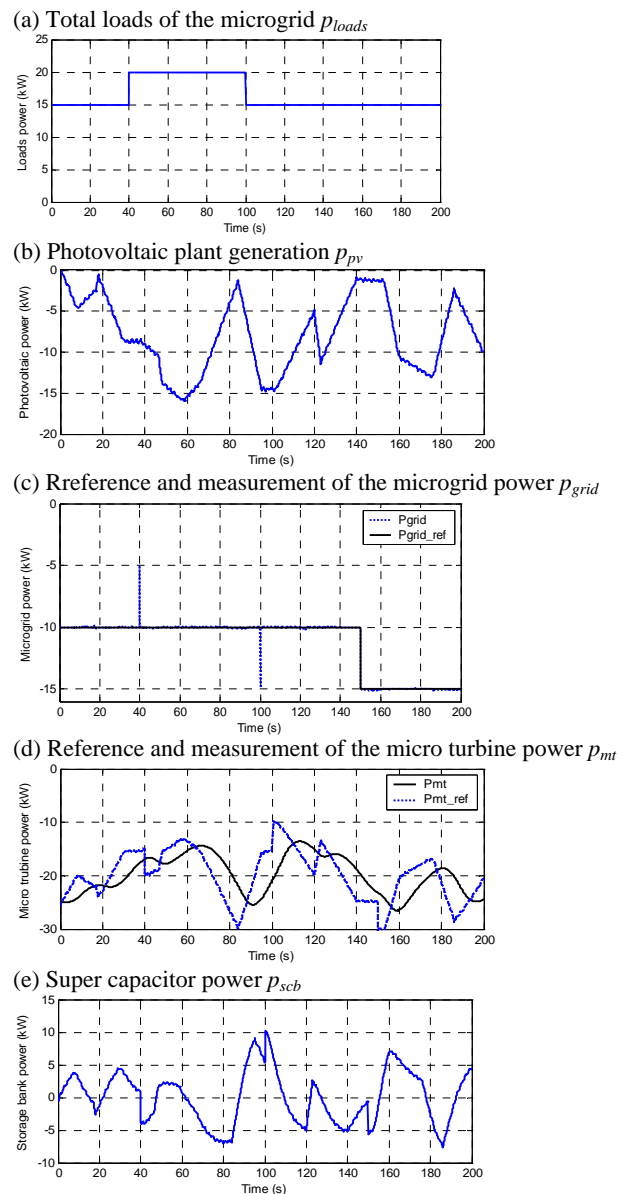

Fig. 3: Simulation results